



ALUMA-FORM®

Pole Line Hardware

Oval Eye Nuts

Features

- Hot dip galvanized to meet ASTM A153

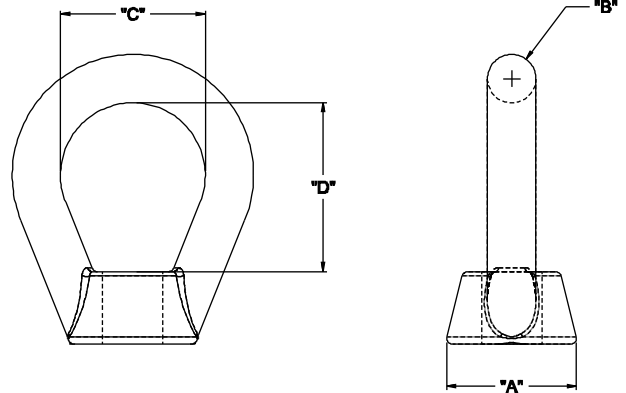

EYE NUTS (OVAL EYE)								
Catalog Name	Description	Diameter	"A"	"B"	"C"	"D"	Weight per 100	Box QTY
AF1092	5/8" OVAL EYE NUT	5/8"	1-3/8"	1/2"	1-1/2"	1-3/4"	50	50
AF1093	3/4" OVAL EYE NUT	3/4"	1-3/8"	1/2"	1-1/2"	1-3/4"	50	50

Thimble Eye Nuts

Features

- Hot dip galvanized to meet ASTM A153

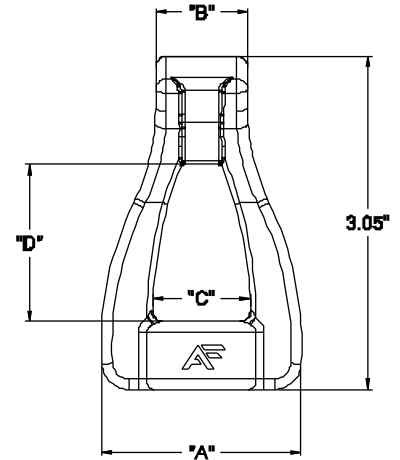

EYE NUTS (OVAL EYE)								
Catalog Name	Description	Diameter	"A"	"B"	"C"	"D"	Weight per 100	Box QTY
AF6510	5/8" THIMBLE EYE NUT	5/8"	1.841"	.843"	.910"	1.438"	72	50
AF6511	3/4" THIMBLE EYE NUT	3/4"	1.841"	.843"	.910"	1.438"	70	50